

# site pod.

## THE WELFARE POD

The Welfare Pod brings together all of the key items associated with good Welfare practice. Hot and cold water are provided for, as well as an integrated microwave and fridge. It also features a 500ml Fire XO extinguisher, hand sanitiser dispenser, waste bin and lockable storage.

The robust, mobile design moves effortlessly around your site over the course of a project, maintaining high standards of care for your team and sub-contractors.



## PRODUCT DETAILS

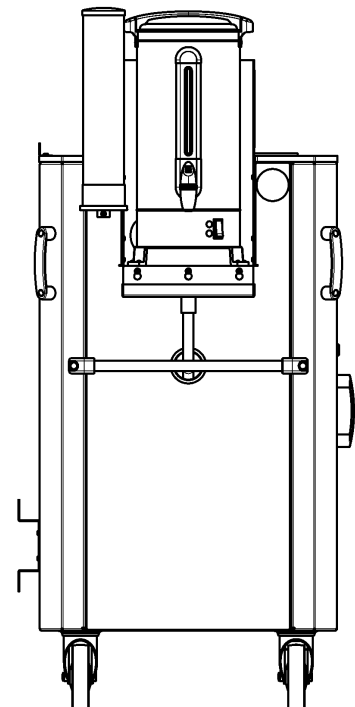
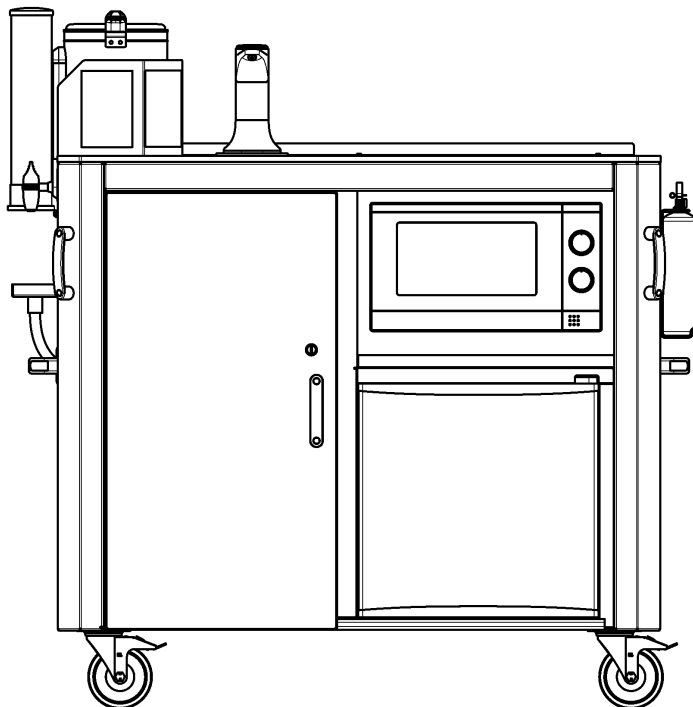

### Features

- Integrated Microwave
- 10 litre hot water urn
- Drinking water dispenser
- 40 litre fridge
- 500ml Fire XO extinguisher
- Hand Sanitiser dispenser
- Lockable storage

### Specification

Height	138cm
Width	135cm
Depth	66cm
Max Weight	80kg

